

## PP3004 QuickLok

Ambient temperature airlock for SEM, FIB/SEM, beamline and vacuum platforms

QuickLok highlights:

- Rapid specimen exchange
- Vacuum and inert gas transfer
- Field-retrofitable to most systems
- Upgrade path to CoolLok
- Custom designed holders available
- 3 year warranty

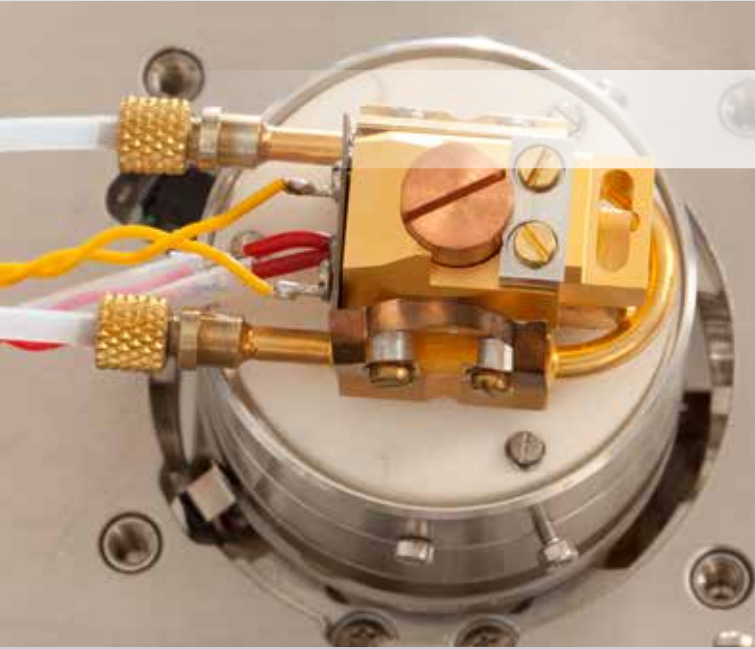

## PP3005 SEMCool

Non-airlock cooling for SEM, FIB/SEM, beamline and vacuum platforms

SEMCool highlights:

- Temperature range down to  $-190^{\circ}\text{C}$
- Off-column cooling with all-day runtime between fills
- Independent cooling of cold stage and cold trap
- Upgrade path to CoolLok
- 3 year warranty

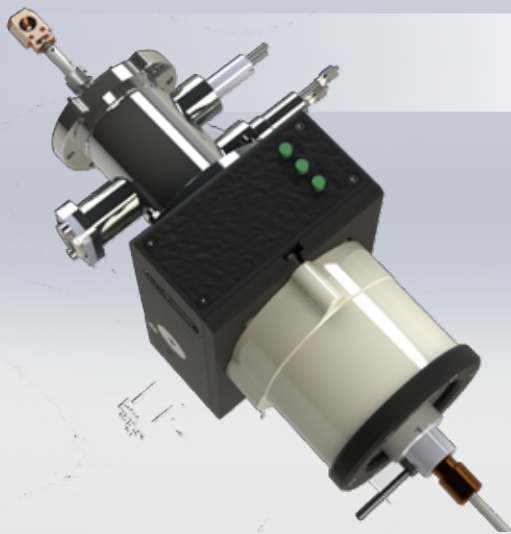

## PP3006 CoolLok

Cryo transfer system for SEM, FIB/SEM, beamline and vacuum platforms

CoolLok highlights:

- Rapid specimen exchange
- Temperature range down to  $-190^{\circ}\text{C}$
- Off-column cooling with all-day runtime between fills
- Independent cooling of cold stage and cold trap
- Vacuum or inert gas transfer
- Rapid specimen freezing option
- 3 year warranty

# Quorum

+44 (0)1323 810981 [www.quorumtech.com](http://www.quorumtech.com)

## PP3004 QuickLok

The QuickLok provides a rapid way of transferring ambient temperature specimens into SEM, FIB/SEM or other suitable vacuum systems. A key feature of the QuickLok is the ability to vacuum transfer specimens that are sensitive to normal environmental conditions. The transfer device uses a sealed vacuum chamber which can be interfaced to a glove box for inert gas transfer or allow vacuum transfer from a wide range of platforms.

### System components

Mounted onto a suitable vacuum chamber port, the QuickLok consists of a loading chamber body with integrated controls for pumping, venting and transfer. A custom-designed interface flange and connections to the pumping system are included (see Pumping below).

The compact vacuum transfer device has an easy-release bayonet fitting to a dovetail-profile specimen holder (shuttle). Standard shuttles are included but optional holders allow a range of specimen types to be handled.

Inside the microscope is a stage to accept the specimen shuttle. To aid specimen exchange an interlocked LED chamber light is mounted to the inside of the QuickLok interface.

### Using the QuickLok

The specimen is mounted on a suitable holder and the transfer device fitted onto the QuickLok. The airlock and transfer device are then evacuated to a pre-set vacuum and the gate valve opened. The specimen is then guided onto the microscope stage.

For transfer from other vacuum systems, or a glove box, additional interface flanges are available on request.

### Pumping

An oil-free turbomolecular pumping station (see Pumping Options).

## PP3005 SEMCool

The SEMCool is based on the PP3006 CoolLok but without the PP3004 QuickLok components. It is designed for cryogenic applications where airlock exchange of specimens into the microscope is not required.

### System components

Exactly as the PP3006 CoolLok but without the airlock and transfer device.

### Using the SEMCool

Vent the SEM, locate specimen holder on the cold stage, re-pump the SEM and then cool down to the required temperature. To exchange specimen, warm to above 0°C and vent the SEM.

### Pumping

The SEMCool requires a rotary pump to periodically evacuate the vacuum isolated lines (see Pumping Options).



Vacuum/inert gas transfer device and airlock



SEM stage and specimen shuttle



Transfer device and specimen holder

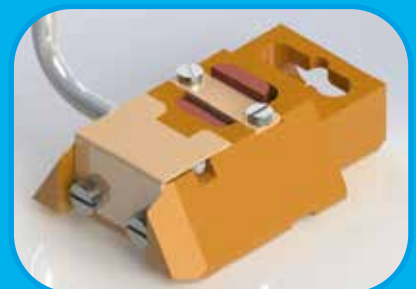
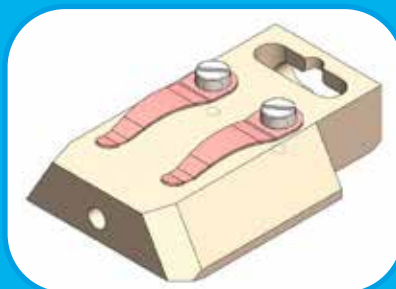

Examples of specimen holders

# PP3006 CoolLok

## Overview

The CoolLok offers rapid transfer and cryo temperature observation of specimens for SEM, FIB/SEM, beamline or other vacuum systems. Applications include thermal protection of beam-sensitive specimens and low temperature observation of materials such as plastics, polymers, low-K dielectrics and hard-soft mixtures. The system can also be used for inert gas transfer of ambient temperature specimens from a glove box.

### Rapid freezing station (24425)

As standard, CoolLok specimen freezing is by contact with the microscope cold stage following transfer and therefore freezing rates are relatively slow. This is suitable for hard, non-hydrated specimens but for liquid-based material rapid freezing is essential to reduce the detrimental effects of ice crystal growth and to allow through-vacuum transfer onto the cold stage.

For these applications the optional 24425 nitrogen slush freezing station is required. However, for many applications (especially lifesciences) cold fracturing and sputter coating are essential process steps and require the advanced capabilities of the Quorum PP3010 – a full cryo preparation system.

## System components

### Vacuum airlock cold gas feedthrough

Mounted onto a suitable vacuum chamber port, the CoolLok consists of a loading chamber body with built-in controls for pumping, venting and transfer. A custom-designed interface flange to the vacuum chamber and connections and fittings to the pumping system are included (see Pumping below). The interface has cold nitrogen gas feeds to and from the microscope cold stage and cold trap.

### Specimen holders and transfer device

The compact vacuum transfer device has an easy-release bayonet fitting to a dovetail-profile specimen holder (shuttle). Standard shuttles are included but optional holders allow a range of different specimen types to be handled.

### Cold stage and cold trap

A highly stable, thermally isolated, nitrogen gas-cooled cold stage attaches to the microscope stage. The location and shape of the cold trap is tailored to suit the internal geometry of the microscope. Both cold stage and cold trap are capable of reaching temperatures down to  $-190^{\circ}\text{C}$  with a stability of  $<0.5^{\circ}\text{C}$ . For easy specimen exchange an LED chamber light is fitted. The cold stage connects to the microscope stage using an adaptor and has a dovetail fitting to accept a specimen holder. When not in use the cold stage is uncoupled and stored within the chamber with the gas and electrical fittings connected.

### Cooling dewar, trolley and controller

The cold stage and cold trap are cooled by a remotely-positioned, vacuum isolated 30 litre dewar and heat exchanger assembly which at normal operating temperatures can run for up to 24 hours between fills. The gas lines between the dewar and the microscope interface are vacuum isolated for maximum thermal efficiency. The cooling dewar sits on a floor-mounted trolley which also houses the monitor/controller for cold stage and monitor for cold trap, plus nitrogen gas flow controllers.

## Using the CoolLok

The specimen is mounted on a suitable holder (shuttle) and the transfer device fitted onto the airlock and the dead space evacuated to a pre-set vacuum level. The gate valve is opened and the specimen guided onto the microscope stage. For transfer from other vacuum systems, or a glove box, additional interface flanges are available on request. Vacuum transfers can be made from the optional 24425 trolley-mounted nitrogen slush freezing station if fitted.

## Pumping

The QuickLok requires either an oil-free turbomolecular pumping station (see Pumping Options).



PP3006 installation example



Nitrogen gas cooled stage



Cold trap – adapted to installation



Heat exchanger and dewar



Slushy LN<sub>2</sub> freezing option (24425)



Heat exchanger and dewar



Temperature controller

## Ordering Information

**NB:** For a full quotation, including on-site installation and customer training, please contact Quorum

### PP3004 QuickLok ambient temperature transfer system

#### Consisting of:

Airlock assembly. Pump, vent and transfer controls, gate valve and fittings to the pumping system (see: Pumping below). Custom designed interface flange to the microscope vacuum chamber.

Microscope dovetail stage to accept specimen shuttle. LED chamber light (interlocked)

12340 specimen transfer device for vacuum or inert gas transfer

Specimen holders. 20720 specimen shuttle with holding clips, 12434 specimen shuttle (blank), AL200077B specimen shuttle (to hold a 10 mm Ø specimen stub), E7402 blank 10 mm Ø stub – packet of 10

### PP3005 SEMCool non-airlock low temperature system

#### Consisting of:

Nitrogen gas cooled cold stage with heater and sensor and cold trap with temperature sensor. Temperature controllable with a range down to -190°C, 30 litre liquid nitrogen dewar with trolley, heat exchanger and LED chamber light. Pump fittings (see: Pumping below).

Temperature and nitrogen gas flow controller mounted on the dewar trolley.

Specimen holders. 3 x AL200077B specimen shuttle (to hold 10 mm Ø cryo stubs), 12434 blank specimen shuttle, 20720 specimen shuttle with holding clips, E7402 blank 10 mm Ø stub (packet of 10), 5 x E7449-7 multi-purpose specimen stub. Note: other holders available. Specimen mounting compounds (colloidal graphite and Tissue-Tek®)

### PP3006 CoolLok cryo transfer system

#### Consisting of:

Airlock assembly. Pump, vent and transfer controls, gate valve and fittings to the pumping system (see: Pumping below). Custom designed interface flange to the microscope vacuum chamber.

Cooling system. Nitrogen gas cooled stage with heater and sensor and cold trap with temperature sensor. Temperature controllable with a range down to -190°C, 30 litre liquid nitrogen dewar with trolley, heat exchanger and LED chamber light.

12340 specimen transfer device

Specimen holders. 3 x AL200077B specimen shuttle (to hold 10 mm Ø cryo stubs), 12434 blank specimen shuttle, 20720 specimen shuttle with holding clips, E7402 blank 10 mm Ø stub (packet of 10), 5 x E7449-7 multi-purpose specimen stub. Note: other holders available

Specimen mounting compounds (colloidal graphite & Tissue-Tek®), interlock cable and pump fittings

## Pumping Options

The PP3004 QuickLok and PP3006 CoolLok require a high vacuum turbomolecular pumping station.

The PP3005 requires a rotary pump for evacuating the vacuum isolated gas lines

13034 Pfeiffer Duo 6 – 5 m<sup>3</sup>/hr rotary vacuum pump with oil mist filter

24426 Pfeiffer HiCube 80 – turbomolecular and diaphragm pumping system

## Options and accessories

24425 Rapid cooling station (for PP3006 only). Consists of a floor-mounted trolley, liquid nitrogen freezing chamber mounted into the work surface which interfaces to the cryo transfer device, connections to vacuum pump (order pump separately)

PP7450 /60L Pressurised (60 L) LN<sub>2</sub> dewar. Boil-off nitrogen gas is used for cooling the stage and cold trap (PP3005 and PP3006 only)

13296 Sircal in-line gas dryer. Helps to reduce water content of nitrogen gas supply

Specimen holders Contact Quorum for a complete list

## Specifications

	PP3004	PP3005	PP3006
<b>Temperature</b>	Ambient	RT to -190°C	RT to -190°C
<b>Cooling runtime</b>	N/A	Up to 24hrs	Up to 24hrs
<b>N<sub>2</sub> dewar capacity</b>	N/A	30 litres	30 litres
<b>Cool down time to -190°C*</b>	N/A	*Operating under standard laboratory conditions <15 minutes	<15 minutes
<b>Rapid freezing (slushy LN<sub>2</sub>)</b>	N/A	Optional (24429)	Optional (24429)
<b>Dewar trolley footprint</b>	N/A	50 x 50 cm	50 x 50 cm
<b>Airlock weight</b>	2.5 kg	2.5 kg	2.5 kg
<b>Pumping requirements</b>	Turbo Pump	Rotary Pump	Turbo Pump
<b>Nitrogen gas</b>	For venting and valve operation	Venting and cooling	Venting and cooling
<b>Power requirements (excluding pump)</b>	300 W	300 W	300 W
<b>Maximum specimen size</b>	Flat specimens up to 23 x 26 mm. For taller specimens the maximum height will reduce from a mid-point of 9 mm. Please contact Quorum for more details		

This document was updated Aug 2018. While every effort has been made to ensure accuracy, no responsibility can be accepted for errors or omissions. Data may change, as well as legislation and you are strongly advised to obtain copies of the most recently issued regulations, standards and guidelines. This document is not intended to form the basis of a contract. Quorum has a policy of continuous product improvement and reserves the right to change specifications without notice. © 2018 Quorum Technologies Limited. All rights reserved.  
QuickLok/SEMCool/CoolLok v4 - June 2021



Quorum Technologies Ltd, Judges House, Lewes Road, Laughton, Lewes, East Sussex BN8 6BN UK  
T: +44(0)1323 810981 E: sales@quorumtech.com www.quorumtech.com